

---

# Research Report

---

## Homogeneous Scoring of Single-Nucleotide Polymorphisms: Comparison of the 5'-Nuclease TaqMan<sup>®</sup> Assay and Molecular Beacon Probes

BioTechniques 28:732-738 (April 2000)

**I. Täpp, L. Malmberg, E. Rennel, M. Wik and A.-C. Syvänen**  
Uppsala University, Uppsala, Sweden

### ABSTRACT

*Homogeneous assays based on real-time fluorescence monitoring during PCR are relevant alternatives for large-scale genotyping of single-nucleotide polymorphisms (SNPs). We compared the performance of the homogeneous TaqMan<sup>®</sup> 5' nuclease assay and the Molecular Beacon assay using three SNPs in the human estrogen receptor gene as targets. When analyzing a panel of 90 DNA samples, both assays yielded a comparable power of discrimination between the genotypes of a C-to-T transition in codon 10 and a G-to-A transition in codon 594 of the estrogen receptor gene. The Molecular Beacon probes distinguished better than the TaqMan probes between homozygous and heterozygous genotypes of a C-to-G transversion in codon 325. The sensitivity of detecting one allele, present as a minority in a mixed sample, varied between the SNPs and was similar for both assays. With the Molecular Beacon assay, the measured signal ratios were proportional to the amount of the minor allele over a wider range than with the TaqMan assay at all three SNPs.*

### INTRODUCTION

Sequence differences between individuals at single nucleotide positions (single-nucleotide polymorphisms or SNPs) are estimated to occur in our genome with a frequency of one out of a few hundred nucleotides (3,22). Efforts are in place to identify dense sets of SNPs to serve as markers in the search for genes underlying common, multifactorial diseases by association studies or genome-wide linkage disequilibrium mapping (18). When the genes and their variants that predispose to multifactorial diseases become known, a growing number of SNPs will be routinely analyzed to diagnose the disorders. Moreover, the analysis of allelic variants of genes that encode drug metabolizing enzymes or drug receptors will be important in the future development of new therapeutic agents (14). The high-throughput technology that provides reliable and reproducible genotyping of SNPs is a prerequisite for meeting these challenges of disease genetics and pharmacogenetics.

All current methods for analyzing SNPs by PCR rely on amplification of the DNA region that spans the SNP to achieve sufficient sensitivity and specificity for detecting single-base variations in the complexity of the human genome. Homogeneous assays without separation steps that are performed and monitored during the amplification are a promising approach towards fully automated, large-scale PCR-based analysis. The homogeneous 5'-nuclease assay, also known as the TaqMan<sup>®</sup> assay

(8,11) and the Molecular Beacon assay were originally designed for real-time detection and quantification of nucleic acid sequences during PCR. However, these assays are also applicable to the genotyping of SNPs (11,20). A key requirement of a SNP genotyping method is that it distinguishes unequivocally between the allelic variants present in homozygous and heterozygous form.

In the present study, we compare the performance of the TaqMan and the Molecular Beacon assays by using three SNPs in the estrogen receptor gene (17) as targets, and analyzing 90 DNA samples that represent all three genotypes at each variable position.

### MATERIALS AND METHODS

#### DNA Samples

Analyzed were a set of 90 DNA samples extracted from EDTA blood of Swedish persons by using the Wizard<sup>®</sup> genomic DNA purification kit (Promega, Madison, WI, USA). The samples were initially genotyped using solid-phase mini-sequencing in a microplate format (19).

#### Primers and Probes

The PCR primers and probes for the SNPs in codon 10, 325 and 594 were designed based on the known cDNA sequence of the estrogen receptor gene (GenBank<sup>®</sup> Accession No. M12674) (6). To perform a fair comparison between the two assays, we contacted Dr.

**Table 1. Probe and Primer Sequences**

Probe or primer	Sequence
MB codon 10	5'-FAM-gcgaggAAAGCATCCGGGATGGC <b>c</b> ctgc-DABCYL-3' 5'-TET-gcgaggAAAGCATCTGGGATGGC <b>c</b> ctgc-DABCYL-3'
MB codon 325	5'-FAM-ccaagcGAGCCCCC <b>C</b> ATACTCTAgcttgg-DABCYL-3' 5'-TET-ccaagcGAGCCCCC <b>G</b> ATACTCTAgcttgg-DABCYL-3'
MB codon 594	5'-FAM-gcgaccCCTGCCAC <b>A</b> GTCTGAGAggtcgc-DABCYL-3' 5'-TET-gcgaccCCTGCCAC <b>G</b> TCTGAGAggtcgc-DABCYL-3'
TQ codon 10	5'-FAM-CCAAAGCATCCGGGATGGCC-TAMRA-3' 5'-TET-ACCAAAGCATCTGGGATGGCC-TAMRA-3'
TQ codon 325	5'-FAM-TGCTGAGCCCCC <b>C</b> ATACTCTATTC-TAMRA-3' 5'-TET-TGCTGAGCCCCC <b>G</b> ATACTCTATTC-TAMRA-3'
TQ codon 594	5'-FAM-TTCCCTGCCAC <b>A</b> GTCTGAGAGCTC-TAMRA-3' 5'-TET-TCCCTGCCAC <b>G</b> TCTGAGAGC-TAMRA-3'
F-primer codon 10	5'-CCACGGACCATGACCATGA-3'
R-primer codon 10	5'-TCTTGAGCTGCGGACGGT-3'
F-primer codon 325	5'-CAGATGGTCAGTGCCTTGTGGA-3'
R-primer codon 325	5'-CGAAGCTTCACTGAAGGGTCTGG-3'
F-primer codon 594	5'-CGCATTCTTGCAAAAGTATTACA-3'
R-primer codon 594	5'-AAATGCAGCAGGGATTATCTGAAC-3'

MB = Molecular Beacon probe; TQ = TaqMan probe; F-primer = forward PCR primer; R-primer = reverse PCR primer.  
Lowercase letters represent the sequence in the stem structure of the MB probe, and bold letters represent the polymorphic nucleotides.

Sanjay Tyagi at the Public Health Research Institute in New York for advice. He is the inventor and major developer of the Molecular Beacon probes. The TaqMan probes were designed for us by Dr. Lars Melin, the senior technical expert at PE Biosystems in Sweden. We used a DNA folding program ([www.ibc.wustl.edu-zuker](http://www.ibc.wustl.edu-zuker)) to estimate the stability of the stem and loop structure of the Molecular Beacon probes. Table 1 gives the primer and probe sequences with their modifications. The Molecular Beacon probes were synthesized by Interactiva Biotechnologie, and the TaqMan probes were obtained from PE Biosystems (Foster City, CA, USA).

### Molecular Beacon Assay

Ten nanograms of genomic DNA were amplified by PCR in a 25  $\mu$ L reaction containing 1.25 U of *Taq* Gold™

DNA polymerase (PE Biosystems), 3.5 mM MgCl<sub>2</sub>, 250  $\mu$ M of dNTPs (Amersham Pharmacia Biotech, Uppsala, Sweden), 1  $\mu$ M each PCR primer in DNA polymerase Buffer A containing the Rox dye supplied by PE Biosystems. The two Molecular Beacon probes for codons 10 and 325 were included in the reaction mixture at 0.34  $\mu$ M, and those for codon 594 were used at 0.68  $\mu$ M (the Fam-labeled probe for the A-allele) and 0.14  $\mu$ M (the Tet-labeled probe for the G-allele). The amplification conditions consisted of an initial incubation step of 95°C for 10 min, followed by 40 cycles of 95°C for 30 s, 60°C (codon 10), 55°C (codon 325) or 64°C (codon 594) for 1 min and 72°C for 45 s using an ABI Prism™ 7700 sequence detection system (PE Biosystems). The increase in fluorescent signal was registered during the annealing step of the reaction.

### TaqMan Assay

Ten nanograms of genomic DNA were amplified by PCR in a 25  $\mu$ L reaction volume containing 1.25 U of *Taq* Gold DNA polymerase, 5  $\mu$ M MgCl<sub>2</sub>, 250  $\mu$ M of dNTPs (Amersham Pharmacia Biotech), 1  $\mu$ M each of PCR primer and the Fam-labeled TaqMan probes for the SNPs in codon 10 and codon 594 at 0.2  $\mu$ M and the corresponding Tet-labeled probes at 0.1  $\mu$ M concentrations; or both probes for the SNP in codon 325 at 0.1  $\mu$ M concentration in DNA polymerase Buffer A containing the Rox dye. In addition, the reaction mixtures for codons 325 and 594 contained 5% glycerol. The amplification conditions consisted of an initial incubation step of 95°C for 10 min, followed by 40 cycles at 95°C for 15 s, 62°C (codon 10 and 325) or 64°C (codon 594) for 1 min using an ABI Prism 7700 sequence detection system. The increase in fluorescent signal was registered during the combined annealing and extension steps of the reaction.

### Interpretation of Results

The signals of the Tet and Fam fluorophores, which were corrected for the fluorescence of the passive Rox-labeled reference oligonucleotide obtained at the last cycle of the amplification plot in the ABI Prism 7700 instrument, were used without further normalization. The genotypes of the samples were assigned by calculating the ratio between the signal from the Tet-labeled probes (detecting the T-allele at codon 10, the G-alleles at codon 325 and at codon 594) and the sum of the signals from the Tet and Fam labeled probes [ $R = \text{Tet}/(\text{Tet} + \text{Fam})$ ]. The difference in signal ratios between the genotypes was used for comparing the power of discrimination between genotypes of the two methods.

### RESULTS

Both the TaqMan and the Molecular Beacon assays are based on real-time detection of allele-specific hybridization of two fluorescently labeled probes during PCR, but different molecular strategies are used to generate the fluor-

# Research Report

escence signals. Figure 1 illustrates the principal aspects of the two methods. When the practical performance and cost of labor are considered, the two assays are comparable. They both involve PCR amplification in the presence of the two allele-specific probes that are labeled with different fluorophores in a single reaction vial with online fluorescence monitoring, followed by computer-assisted interpretation of the fluorescence data. The cost of the reagents and consumables for both assays are also similar.

We compared the TaqMan and Molecular Beacon assays by analyzing a panel of DNA samples, obtained from Swedish individuals, for SNPs in codon 10 (TCT vs. TCC), codon 325 (CCC vs. CCG) and codon 594 (ACA vs. ACG) of the estrogen receptor gene. Initially, the optimal annealing temperatures for the Molecular Beacon probes were estimated by measuring the thermal annealing and denaturation profiles of hybrids formed with synthetic oligonucleotide targets using the ABI Prism 7700 instrument (5). The performance of each assay was then optimized with respect to probe concentrations and ratios, PCR annealing temperature and the presence of glycerol in the PCR mixture, essentially as recommended in the ABI Prism 7700 users' bulletin. The conditions yielding the largest differences in signal ratios between the genotypes (see the Materials and Methods section) are the results of these preliminary experiments.

Using the optimized procedures for the TaqMan and Molecular Beacon assays, the three SNPs in the estrogen receptor gene were typed in 90 DNA samples. Figure 2 illustrates the online fluorescence monitoring for three samples of different genotypes analyzed with both types of probes. Figure 3 summarizes the genotyping results for the whole panel of samples. These results are expressed as the ratio between the signal from the probe labeled with Tet and the sum of the signals from the Tet- and the Fam-labeled probes. At codons 10 and 594, these signal ratios  $[Tet/(Tet + Fam)]$  fell into three distinct categories that define the genotypes unequivocally using both the Molecular Beacon and TaqMan probes. Both types of probes yielded a comparable

power of discrimination between the homozygous and heterozygous genotypes with differences in signal ratios ranging from 0.3–0.5 and little variation in signal ratios between samples of the same genotype (Figure 3).

However, at codon 325, the Molecular Beacon probes distinguished more reliably between the genotypes than the TaqMan probes. This was because of the high cross-hybridization of the TaqMan-G allele-specific probe with the C-allele. This result is reflected in Figure 3 as high  $[G_{Tet}/(G_{Tet} + C_{Fam})]$  ratios and a large variability in signal ratios between the individual samples from CC homozygotes that caused mistyping of five samples based on their signal ratios, while the Molecular Beacon probes yielded correct results for all samples. The difficulty in distinguishing the CC and CG genotypes was encountered again when the whole panel of samples was retyped with the TaqMan probes. It should be noted that the five nucleotides flanking the C-to-G transversion in

codon 325 on the 5' side are all Cs.

To investigate how well the two homogeneous detection methods resolved differences, we studied the ability of the Molecular Beacon and TaqMan assays to detect polymorphic nucleotides that were present as a minority of the DNA sample. For this comparison, we prepared a twofold dilution series for each of the three SNP sites. Genomic DNA homozygous for one of the alleles was diluted into DNA homozygous for the other allele and the mixed samples were subjected to genotyping with both assays. The sensitivity of detecting a minority sequence variant was defined as the smallest percentage of the sequence variant that could be distinguished based on its  $[Tet/(Tet + Fam)]$  ratio, minus one SD over the  $[Tet/(Tet + Fam)]$  ratio, plus one SD from the corresponding homozygote sample (0% of the variant sequence), as shown in Figure 4. At codon 10, the smallest detectable proportion of the T-allele was 25% for the TaqMan probes and 6.3%

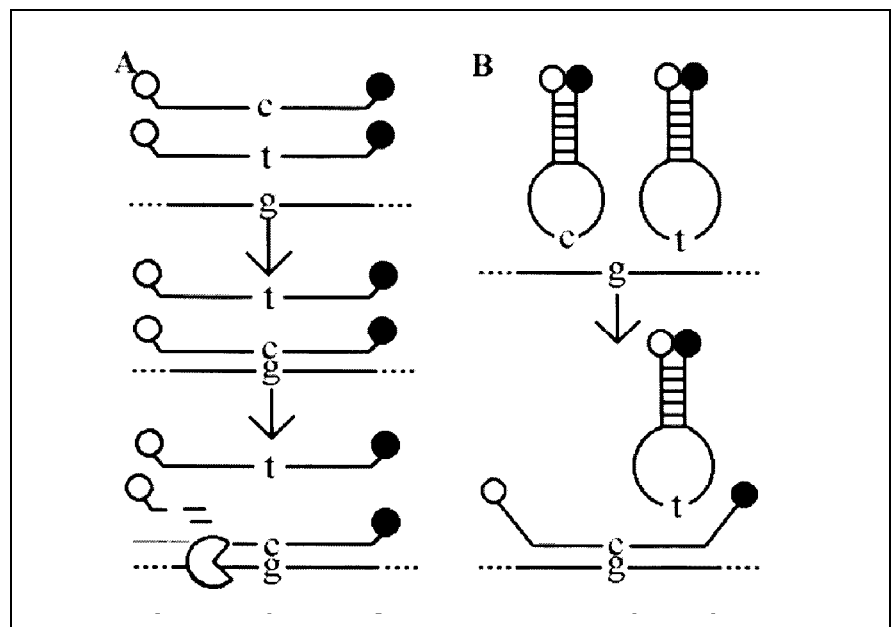
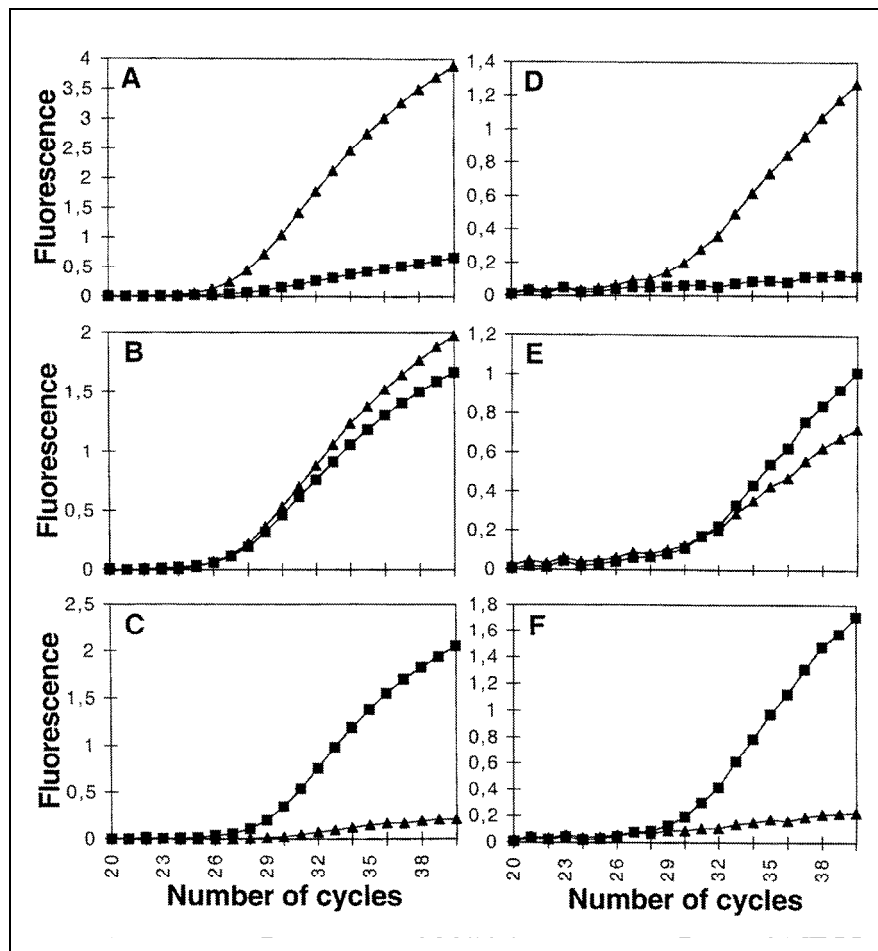

**Figure 1. Mechanisms of the TaqMan and Molecular Beacon assays illustrated by detecting a G-allele.** (A) The TaqMan assay is based on FRET between a fluorescent donor-acceptor pair with overlapping emission-absorption spectra. The fluorescence of the 5'-donor fluorophore is quenched by the 3'-acceptor when the TaqMan probe molecules are hybridized to their targets. Degradation of the probe by the 5'-nuclease activity of the Taq DNA polymerase releases the 5'-reporter fluorophore from the vicinity of the 3'-quencher so that an increase in fluorescence during the consecutive extension step of PCR is seen. (B) In the Molecular Beacon assay, the probes carrying 5'-fluorescent reporter molecules and 3'-quencher molecules are allowed to hybridize to their targets during the annealing step of the PCR, which generates an increase in fluorescence. Unhybridized probe molecules do not emit fluorescence because the probe molecules form a hairpin structure that brings the 5'-fluorophore into the close vicinity of the 3'-quencher molecule. In both panels A and B, an increase in fluorescence is observed from the probe specific for the G-allele.

for the Molecular Beacon probes. At codon 594, both probes could detect 6.3% of the G-allele. At codon 325, as little as 1.6% and 3.1% of the G-allele were detectable using the TaqMan and Molecular Beacon probes, respectively. We observed the range in which the twofold differences in the amount of the minority sequence variants could be resolved, based on the [Tet/(Tet + Fam)] ratio ( $\pm$  one SD) and a linear relationship between the signal ratio and the proportion of the minority allele. It varied between the three SNPs and was wider using the Molecular Beacon probes than the TaqMan probes at each of the SNP sites. At codon 325, the Molecular Beacon assay was quantitative over the whole range above 3.1%.

## DISCUSSION

In the present study, the Molecular Beacon assay gave more reliable genotyping results in a GC-rich target region. The Molecular Beacon probes appeared to be more robust in resolving sequence variants because they allowed sensitive, quantitative detection of minority sequence variants over a wider range than the TaqMan assay at each of the analyzed SNP. The following two features of the Molecular Beacon probes contribute to their apparent greater power of allele discrimination. First, the Molecular Beacon probes hybridize to their targets during the annealing step of PCR. Hence, their lower hybridization stability increases their



**Figure 2.** Examples of data obtained with the TaqMan and Molecular Beacon assays from six samples of different genotype. Panels A–C show results from genotyping codon 10 using TaqMan probes, and panels D–F show results from genotyping codon 325 using Molecular Beacons. The fluorescence signals are plotted as a function of cycle number. In each panel, the triangles represent signals from the Fam-labeled probe and the squares represent signals from the Tet-labeled probes. The genotypes of the analyzed samples are: (A) homozygote CC; (B) heterozygote CT; (C) homozygote TT; (D) homozygote CC; (E) heterozygote CG and (F) homozygote GG.

# Research Report

sensitivity to mismatches, as compared to the TaqMan probes that must remain hybridized during the extension step of PCR. Structural analogues of thymidine can be included in the sequence of TaqMan probes to increase their melting temperature, potentially allowing the use of shorter probes with improved

sensitivity to mismatches (9). The tendency of the Molecular Beacon probes to adopt the hairpin stem-loop structure is an additional factor that destabilizes their mismatch hybridization (20). Second, the increase in fluorescence of hybridized Molecular Beacon probes when compared to the fully quenched

state in the hairpin-loop conformation is larger than the increase in fluorescence of the TaqMan probes when the donor fluorophore is cleaved from the hybridized probe molecules.

However, a potential and practical feature of the TaqMan assay is to use endpoint detection at room temperature, which is not possible with the Molecular Beacon probes that are fluorescent only at the elevated hybridization temperature. The TaqMan assay is currently limited to two probes per assay because the fluorescence resonance energy transfer (FRET) requires fluorescent donor-acceptor pairs that cover a large part of the available wavelengths (13), while four or more differentially labeled Molecular Beacons can be measured in the same reaction because the dimethylaminophenylazo benzoic acid (DABCYL) moiety used as a quencher is nonfluorescent (20). Preliminary experiments using TaqMan probes with nitrothiazole blue as a non-fluorescent quencher that can be combined with multiple fluorescent dyes have recently been described (12).

In solid-phase assay formats, DNA polymerase-assisted, mini-sequencing primer extension allows better allele discrimination than hybridization with allele-specific probes (16). It also requires less optimization of reaction conditions than hybridization-based assays (19). A homogeneous FRET-based single-nucleotide primer extension method, called template-directed dye terminator incorporation (TDI), has recently been devised for genotyping SNPs (2). In the TDI assay, FRET between a 5'-fluorescence-labeled detector primer and an incorporated fluorescent ddNTP is measured after cycled mini-sequencing reactions.

A drawback of the homogeneous TDI assay compared with the TaqMan or Molecular Beacon assays is that primers and dNTPs of the PCR mixture, present in a large molar excess over the detector primer and fluorescent ddNTPs, have to be removed or inactivated before the detection reaction. This drawback is avoided in other enzyme-assisted homogeneous assays that are based on allele-specific ligation of dye-labeled oligonucleotides performed in a similar manner and using FRET as detection principle (1), and in homogeneous assays based

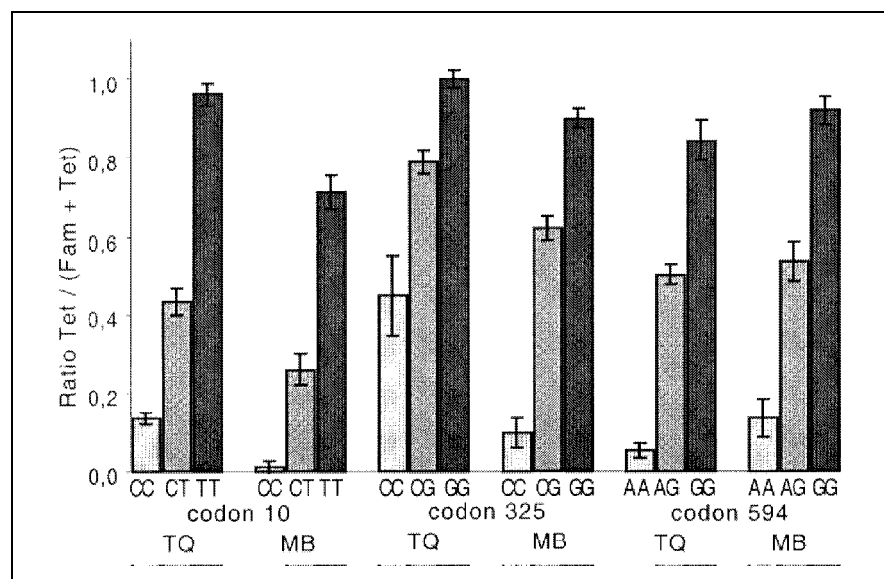

**Figure 3. Result from genotyping 90 samples at codons 10, 325 and 594 of the estrogen receptor gene using TaqMan and Molecular Beacon probes.** The vertical bars are the mean values of the ratios between fluorescence signals from the Tet-labeled probes (detecting the T-allele at codon 10 and the G-allele at codon 325 or 594) and the sum of the fluorescence signals from the Tet-labeled and Fam-labeled probes (detecting the C-allele of codon 10 or 325 and the A-allele at codon 594) for the samples of each of the genotypes indicated below the figure. TQ denotes results with the TaqMan probes, and MB denotes results with the Molecular Beacons. The number of samples representing homozygotes for the rarer alleles were: 18 TT homozygotes at codon 10, 6 GG homozygotes at codon 325 and 5 AA homozygotes at codon 594. Vertical lines indicate the standard deviations.

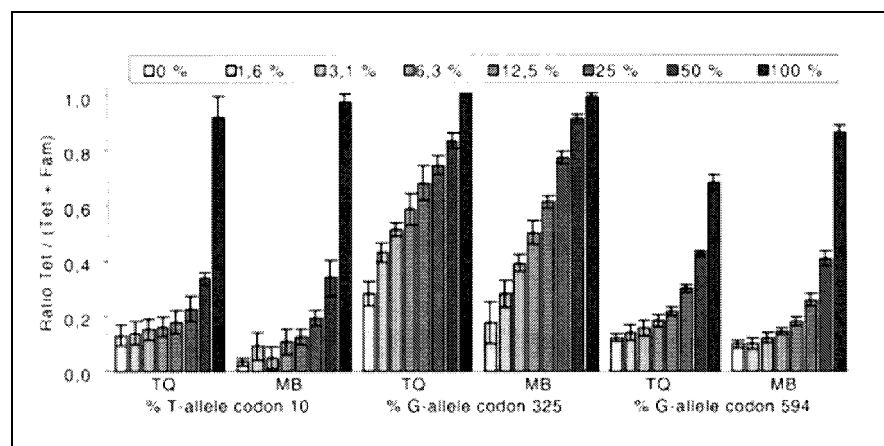

**Figure 4. Result from genotyping mixed samples containing varying proportions of the codon 10 T-allele, the codon 325 G-allele or the codon 594 G-allele of the estrogen receptor gene using TaqMan and Molecular Beacon probes.** The bars represent the ratios between the fluorescence signals from the Tet-labeled probes and the total fluorescence from the Tet- and Fam-labeled probes as in Figure 3. Mean values of five parallel assays and the standard deviations are shown. The percentages of the alleles, represented by the different shades of the bars, are specified in the insert.

# Research Report

on competitive allele-specific PCR amplification with direct fluorescence detection of the formed double-stranded PCR products (4,10).

Homogeneous assays in microplate formats have a high throughput, particularly when a limited number of mutations or SNPs are to be analyzed from large numbers of samples. One way to increase sample throughput is to perform the genotyping using pooled samples, which we have shown in this study to be feasible with the Molecular Beacon probes, at least for some SNPs. In situations when many mutations should be analyzed per sample, microarrays with immobilized probes or primers can increase the throughput of SNP typing (7,16,22). Molecular Beacon probes could also be used in microarray formats because the fluorescence signals originate from intact probe molecules, as has been previously demonstrated using peptide nucleic acid (PNA)-DNA hybrid Molecular Beacons (15). In the 5'-nuclease reaction, the TaqMan probe is degraded and the signals are measured after release into the solution, a step that renders the TaqMan probes incompatible with immobilization on arrays. Significantly miniaturized microplates, together with online fluorescence detection during PCR, may provide an approach for multiplexing both the TaqMan and the Molecular Beacon assays in the near future.

## ACKNOWLEDGMENTS

We thank Drs. Sanjay Tyagi and Lars Melin for their valuable advice on the Molecular Beacon and TaqMan assays, respectively. We are grateful to Dr. Marita Möllenberg (P-E/ABI, Stockholm, Sweden) for generously providing the TaqMan probes. We thank Ms. Karin Johansson for help with the ABI Prism 7700 Sequence Detection System and Drs. Gisela Barbany and Ulf Landegren for helpful discussions.

## REFERENCES

1. **Chen, X., K. Livak and P.Y. Kwok.** 1998. A homogeneous, ligase-mediated DNA diagnostic test. *Genome Res.* 8:549-556.
2. **Chen X., B. Zehnauer, A. Gnirke and P.Y. Kwok.** 1997. Fluorescence energy transfer detection as a homogeneous DNA diagnostic method. *Proc. Natl. Acad. Sci. USA* 94:10756-10761.
3. **Cooper, D.N., B.A. Smith, H.J. Cooke, S. Niemann and J. Schmidtke.** 1985. An estimate of unique DNA sequence heterozygosity in the human genome. *Hum. Genet.* 69:201-205.
4. **Germer, S. and R. Higuchi.** 1999. Single-tube genotyping without oligonucleotide probes. *Genome Res.* 9:72-78.
5. **Giesendorf, B.A.J., J.A.M. Vet, S. Tyagi, E.J.M.G. Mensink, F.J.M. Trijbels and H.J. Blom.** 1998. Molecular Beacons: a new approach for semiautomated mutation analysis. *Clin. Chem.* 44:482-486.
6. **Greene, E.R., P. Gilna, M. Waterfield, A. Baker, Y. Hort and J. Shine.** 1986. Sequence and expression of human estrogen receptor complementary DNA. *Science* 231:1150-1154.
7. **Hacia, J.** 1999. Resequencing and mutational analysis using oligonucleotide microarrays. *Nat. Genet.* 21(suppl.):42-47.
8. **Holland P.M., R.D. Abramson, R. Watson and D.H. Gelfand.** 1991. Detection of specific polymerase chain reaction product by utilizing the 5'→3' exonuclease activity of *Thermus aquaticus* DNA polymerase. *Proc. Natl. Acad. Sci. USA.* 88:7276-7280.
9. **Kuimelis, R.G., K.J. Livak, B. Mullah and A. Andrus.** 1997. Structural analogues of TaqMan probes for real-time quantitative PCR. *Nucleic Acids Symp. Ser.* 37:255-256.
10. **Kyger, E.M., M.D. Krevolin and M.J. Powell.** 1998. Detection of the hereditary hemochromatosis gene mutation by real-time fluorescence polymerase chain reaction and peptide nucleic acid clamping. *Anal. Biochem.* 260:142-148.
11. **Lee, L.G., C.R. Connell and W. Bloch.** 1993. Allelic discrimination by nick translation PCR with fluorogenic probes. *Nucleic Acids Res.* 21:3761-3766.
12. **Lee L.G., K.J. Livak, B. Mullah, R.J. Graham, R.S. Vinayak and T.M. Woudenberg.** 1999. Seven-color, homogeneous detection of six PCR products. *BioTechniques* 27:342-349.
13. **Livak, K.J., S.J.A. Flood, J. Marmaro, W. Giusti and K. Deetz.** 1995. Oligonucleotides with fluorescent dyes at opposite ends provide a quenched probe system useful for detecting PCR product and nucleic acids hybridization. *PCR Meth. Applic.* 4:357-362.
14. **Nebert, D.W.** 1997. Polymorphisms in drug-metabolizing enzymes: what is their clinical relevance and why do they exist. *Am. J. Hum. Genet.* 60:265-271.
15. **Ortiz, E., G. Estrada and P.M. Lizardi.** 1998. PNA molecular beacons for rapid detection of PCR amplicons. *Mol. Cell. Probes* 12:219-226.
16. **Pastinen, T., A. Kurg, A. Metspalu, L. Peltonen and A.-C. Syvänen.** 1997. Minisequencing: a specific tool for DNA analysis and diagnostics on oligonucleotide arrays. *Genome Res.* 7:606-614.
17. **Roodi, N., L.R. Bailey, W.-Y. Kao, C.S. Verrier, C.J. Yee, W.D. Dupont and F.F. Parl.** 1996. Estrogen receptor gene analysis in estrogen receptor-positive and receptor-negative primary breast cancer. *J. Nat. Cancer Inst.* 87:446-451.
18. **Schafer, A.J. and J.R. Hawkins.** 1998. DNA variation and the future of human genetics. *Nat. Biotechnol.* 16:33-39.
19. **Syvänen, A.-C., A. Sajantila and M. Lukka.** 1993. Identification of individuals by analysis of biallelic DNA markers using PCR and solid-phase minisequencing. *Am. J. Hum. Genet.* 52:46-59.
20. **Tyagi, S., D.P. Bratu and F.R. Kramer.** 1998. Multicolor molecular beacons for allele discrimination. *Nat. Biotechnol.* 16:49-53.
21. **Tyagi, S. and F.R. Kramer.** 1996. Molecular beacons: probes that fluoresce upon hybridization. *Nat. Biotechnol.* 14:303-308.
22. **Wang, D.G., J.B. Fan, C.J. Siao, A. Berno, P. Young, R. Sapolsky, G. Ghandour, N. Perkins et al.** 1998. Large-scale identification, mapping, and genotyping of single-nucleotide polymorphisms in the human genome. *Science* 280:1077-1082.

Received 17 May 1999; accepted 1 December 1999.

## Address correspondence to:

Prof. Ann-Christine Syvänen  
Department of Medical Sciences  
Molecular Medicine  
Ing 70, 3tr, Foavd 2  
Uppsala University Hospital  
75185 - Uppsala, Sweden  
Internet: ann-christine.syvanen@medsci.uu.se